

**390-1  
Back Pack  
Vacuum**

**Model:  
C39185-01  
C39185-02**

**OPERATION**

**SERVICE**

**PARTS**

**CARE**

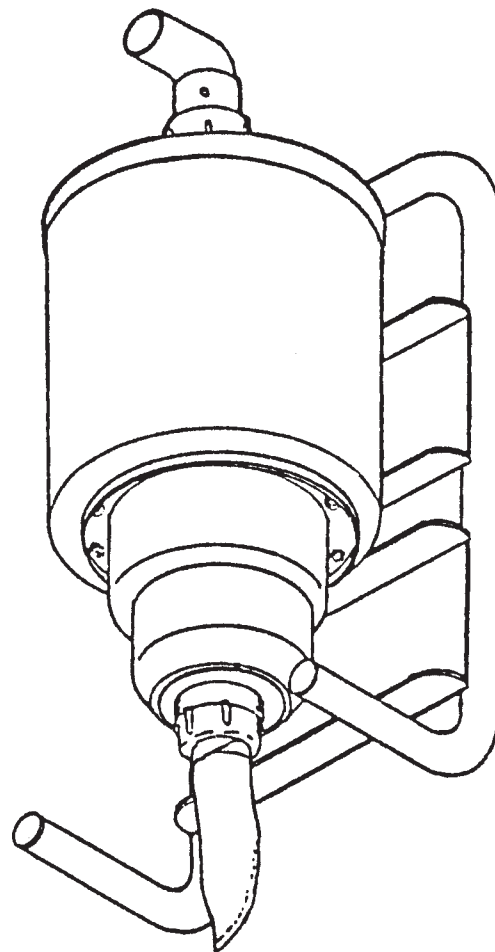

Revised 7/93

***Minuteman***<sup>®</sup>

# OPERATING INSTRUCTIONS

## INSPECTION

Carefully unpack and inspect your machine for shipping damage. Each unit is tested and thoroughly inspected before shipment, and any damage is the responsibility of the delivering carrier who should be notified immediately. Read all instructions carefully before operating.

## WARNING

Electrical shock could occur if used on wet surfaces. Do not expose to rain. Store indoors.

Electrical motors can cause explosions when operated near explosive materials or vapors. Do not operate this machine near flammable materials such as solvents, thinners, fuels, grain dust, etc.

## ELECTRICAL - 115 Volt

This machine is designed to operate on a standard 15 amp. 115 volt, 60 hz, AC circuit. Voltages below 105 volts AC or above 125 volts AC could cause serious damage to the motor.

## ELECTRICAL - 240 Volt

This machine is designed to operate on a standard 16 amp. type L fused 230 volt, 50 hz, AC circuit. Voltages below 200 volts AC or above 250 volts AC could cause serious damage to the motor. I.E.C. Class 1.

## GROUNDING INSTRUCTIONS

To protect the operator from electrical shock, this machine must be grounded while in use. This machine is equipped with an approved three-conductor power cord and grounding type plug to fit the proper grounding type receptacle.

This machine is for use on a nominal 120 volt circuit and has a grounding plug that looks like the plug illustrated in Sketch A. Make sure that the machine is connected to an outlet having the same configuration as the plug. No adapter should be used with this machine.

For equipment rated 150-250 volts: If the machine is provided with an attachment plug as shown in Sketch B, it is intended for use on a 240 volt (nominal) circuit. No adapter is available for this plug.

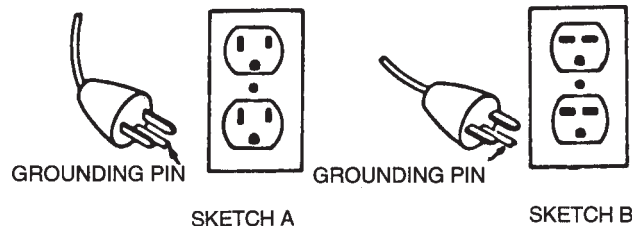

## Parts Listing

ITEM	PART NO	QTY	DESCRIPTION	ITEM	PART NO	QTY	DESCRIPTION
1	381007	1	Back Pack Frame Complete	23	710253	1	SCR-MC 10-32 x .37 STPL
2	806010	1	Bag, Exhaust Air	24	740006	2	Wire Cap 71B
3	381023	1	Connector	25	711543	8	WSR-Helical #10
4	750072	1	Motor Cover Complete	26	711310	1	Nut-Hex 10-32 STPL
5	380004	1	Relief, Strain	27	711351	8	Nut-Acorn 10-32 ST NI
6	381052	1	Clamp, Plastic	28	710153	12	SCR-MC 10-32 x .37 NI PL
7	831713	1	Assembly Cord	30	711124	1	SCR-ST-B 10 x .37 NI
8	832243	1	Switch	31	710593	1	SCR-MC 1/4-20 x 3.00 STPL
9	381021	1	Strap, Carrying	32	711505	2	WSR-Flat 1/4
10	381012	2	Gasket Pad Diecut	33	711544	1	WSR-Helical 1/4
11	381001	1	Vacuum Motor, 115V	34	711316	2	Nut-Hex 1/4-20 STPL
12	380028	2	Brush, Carbon Replacement	35	381031	1	Screen
13	380035	2	Gasket, 4.31 x 5.81 x .19	36	711591	1	WSR-Rubber
14	750094	1	Tank Assembly Complete, Includes Item 15	37	712425	2	Nut-Flanged Wizz 1/4-20
15	761054	2	Latch	38	750002	1	Ground Wire Assembly
16	750136	1	Hose Swivel 381	39	711503	7	WSR-Flat #10
17	805014	1	Cloth Bag	41	710363	3	SCR-RHMS 10-32 x 1.50 STPL
18	381033PKG	1	Bag, Paper Pkg. (10)	42	832206	2	Strain Relief
19	381032	1	Lid Assembly, Includes Item 20	43	832431	1	Bkt. Strain Relief Black
20	380044	1	Lid Gasket, 4/6, 40"	44	711427	9	Nut-Flanged Wizz 10-32
21	715002	1	Decal	45	832126	1	Tube Closure
22	715061	1	General Warning Decal	46	712320	4	WSR-Nylon .22 x .45 x .04
				***	750095	1	Hose Assembly, 1 1/2" x 5'

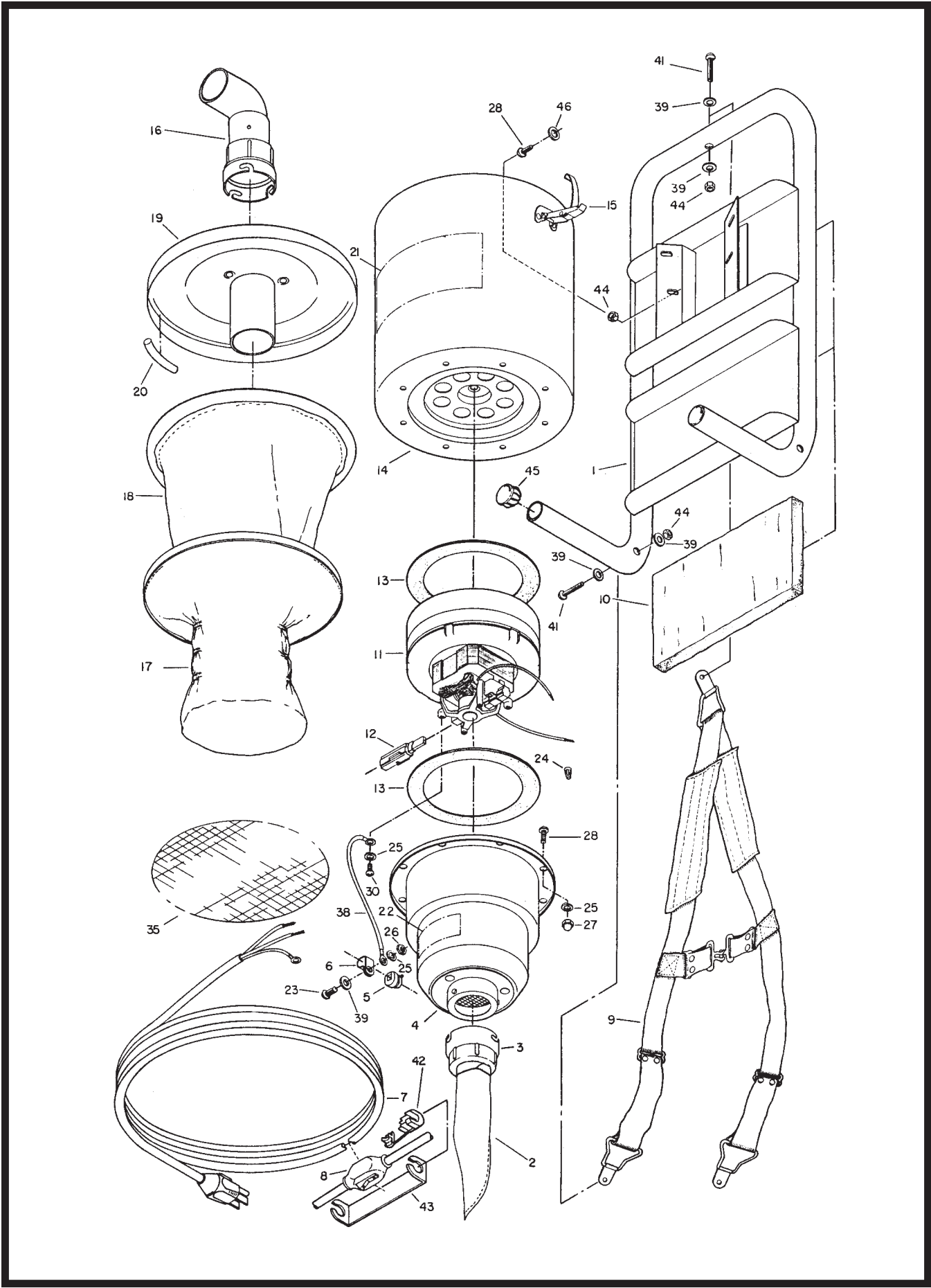

# LIMITED WARRANTY

Minuteman International, Inc. warrants to the original purchaser/user that this product is free from defects in workmanship and materials under normal use and service for a period of three years from date of purchase. In addition, Minuteman International, Inc. will, at its option, honor labor warranty claims for the first 12 months from date of sale, provided such claims are submitted through and approved by factory authorized repair stations. Minuteman International, Inc. will, at its option, repair or replace without charge, except for transportation costs, parts that fail under normal use and service when operated and maintained in accordance with the applicable operation and instruction manuals.

This warranty does not apply to normal wear, or to items whose life is dependent on their use and care, such as belts, cords, switches, hoses, rubber parts, electrical motor components or adjustments. Parts not manufactured by Minuteman International, Inc. such as engines, batteries, battery chargers, hydraulic pumps, and tires are covered by and subject to the warranties and/or guarantees of their manufacturers. Please contact Minuteman International, Inc. for procedures in warranty claims against these manufacturers.

**Special warning to purchaser** — Use of replacement filters and/or prefilters not manufactured by Minuteman International, Inc. or its designated licensees, will void all warranties expressed or implied.

A potential health hazard exists without exact original equipment replacement.

All warranted items become the sole property of Minuteman International, Inc. or its original manufacturer, whichever the case may be.

Minuteman International, Inc. disclaims any implied warranty, including the warranty of merchantability and the warranty of fitness for a particular purpose. Minuteman International, Inc. assumes no responsibility for any special, incidental or consequential damages.

This limited warranty is applicable only in the U.S.A. and Canada, and is extended only to the original user/purchaser of this product. Customers outside the U.S.A. and Canada should contact their local distributor for export warranty policies. Minuteman International, Inc. is not responsible for costs or repairs performed by persons other than those specifically authorized by Minuteman International, Inc. This warranty does not apply to damage from transportation, alterations by unauthorized persons, misuse or abuse of the equipment, use of non-compatible chemicals, or damage to property, or loss of income due to malfunctions of the product.

If a difficulty develops with this machine, you should contact the dealer from whom it was purchased.

This warranty gives you specific legal rights, and you may have other rights which vary from state to state. Some states do not allow the exclusion or limitation of special, incidental or consequential damages, or limitations on how long an implied warranty lasts, so the above exclusions and limitations may not apply to you.

## ***Minuteman***<sup>®</sup>

**World Headquarters**  
Minuteman International, Inc.  
111 South Rohlwing Road  
Addison, Illinois 60101

Minuteman Canada, Inc.  
2210 Drew Road  
Mississauga, Ontario  
L5S 1B1

(630) 627-6900  
FAX (630) 627-1130

(905) 673-3222  
FAX (905) 673-5161

987306  
Printed in U.S.A.